

Flat Track Heavy-Duty Manual System Specifications

GENERAL SPECIFICATIONS: The mobile system utilizes carriages and track to increase storage density by compacting rows of shelving into a single aisle configuration thus converting fixed aisles into storage space thereby greater storage density and capacity is gained. Rows of shelving on a carriage are quickly and easily moved to allow access to a desired row.

FLAT TRACK HEAVY-DUTY MANUAL CARRIAGES: Non-welded unitized carriage frames of front and rear 6063-T6 3-3/8" x 2" aluminum angles with powder coated steel corner or center plates and rubber bump cushions joined by four self-tapping 10-32 x 1-1/2" machine screws to end and intermediate 6063-T6 3-7/32" x 1-7/8" extruded aluminum channels with four patented incorporated channel embossments. Each channel shall house three, positioned under each shelving upright post or back-to-back posts, load bearing 3-1/4" diameter double-flanged 1215 carbon steel wheels. Channels are drilled with computerized axle drilling at all wheel locations to guarantee precision. Steel drive wheels are mounted into the channel via high-speed roller conveyor flange ball bearing assemblies and idler rolling wheels mounted via lubricated and sealed ball bearing race with 3/16" sideways movement with both having precision machined steel axles. For ease of transportation and handling, carriages longer than 144" will be shipped in left and right halves with one factory prepared lap splice per carriage. Splice will consist of 8 1/4-20 x 3/4" hex head machine screws, washers and 1/4-20 nuts to attach 6063-T6 3-3/8" x 2" x 12" aluminum splice angle. Height from floor to top of carriage angle (shelving mounting surface) shall not be more than 4-5/16". The maximum length of the carriage is 12'. The heavy duty manual carriages are rated at 3,000 lbs. The carriages can handle significantly more load, however, 3,000 lbs. is the maximum a person can move comfortably.

72" x 30" Flat Track Heavy-Duty Manual Carriage

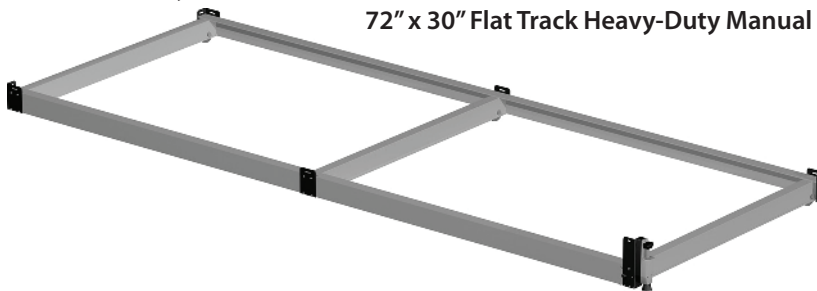

FLAT TRACK: Standard track construction is 3-1/4" wide 6063 aluminum extrusion base with 3/4" x 3/8" 1018 cold roll steel wheel rolling insert to provide 3/4" wide, matched to wheel hardness, wheel-to-insert contact surface for strength and durability. Track shall be top of floor mounted and ADA compliant to eliminate need for deck and ramp and designed to carry a maximum load of 1000 lbs. per linear carriage foot. Track sections will have lap splices, no butt joints nor exhibit movement or deflection during operation of movable carriages. Track will be fastened to the floor through factory drilled and countersunk hole in steel rolling insert, so screw head will be flush or below top of steel, and matching slot in the aluminum extrusion using 1/4 x 2" Hilti Sleeve Anchors placed on average 16" apart. Tracks with center groove that accept a center flanged wheel are not acceptable due to the potential collection of dirt/debris in this groove nor are tracks consisting of steel rail requiring elevated decks acceptable due to additional expense of deck installation.

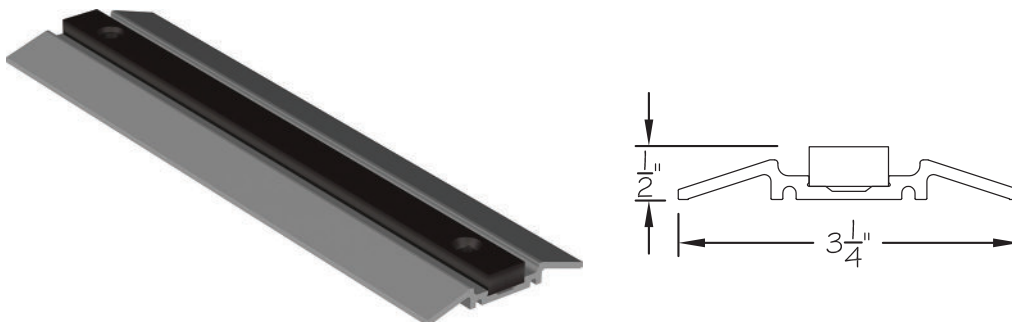

Flat Track Heavy-Duty Manual System Safety Features

RECESSED RUBBER BUMPER: The recessed rubber bumpers ship pre-assembled on carriage. The bumpers are installed on the front and rear channels on one side of the carriage creating a 5/8" gap between carriages.



FLAT TRACK END STOPS: Standard track end stop is 1-1/2" diameter rubber cushion reinforced with an internal steel washer. End stop attached at each end of track run through pre-drilled factory hole with Hilti II 1/4" x 3-1/4" anchor. The end stops prevent the carriages from running off of the track.



IN-TRACK ANTI-TIP SYSTEM: The in-track anti-tip system is an optional safety feature that stabilizes the mobile shelving system and eliminates the potential for a tipping hazard. It is highly recommended for use in Seismic Zones. The anti-tip carriages come assembled with an anti-tip tab and the anti-tip track incorporates a slot along the entire length of the track where the anti-tip tab is inserted during installation.

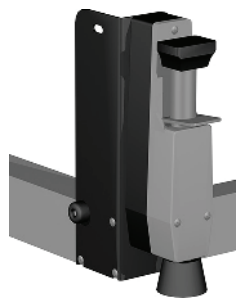

ANTI-DRIFT MECHANISM: The anti-drift mechanism secures carriage in place and prevents the carriage from drifting. The securing mechanism is engaged by simply pressing down the shaft with your foot and is released by flipping the tab up with your foot.

UPRIGHT CAPS: The upright caps securely fasten to the top of the rivet style shelving. The caps are designed with a unique lock tab making it virtually impossible to remove them. The caps protect the user from sharp edges on the top of the uprights.



FLOOR ANCHOR KIT: The floor anchor kit is used to secure stationary shelving to the floor. The anchor kit eliminates a potential tipping hazard and/or movement of the stationary shelving. It is highly recommended for use Seismic Zones.