

Flat Track Mechanical-Assist (SDF) System Specifications

GENERAL SPECIFICATIONS: The mobile system utilizes carriages and track to increase storage density by compacting rows of shelving into a single aisle configuration thus converting fixed aisles into storage space thereby greater storage density and capacity is gained. Rows of shelving on a carriage are quickly and easily moved via a mechanical-assist drive and handle to allow access to a desired row.

FLAT TRACK MECHANICAL ASSIST CARRIAGES: Non-welded unitized carriage frames of 6063-T6 3-3/8" x 2" aluminum angles with powder coated steel corner or center plates and rubber bump cushions joined by four self-tapping 10-32 x 1-1/2" machine screws to end and intermediate 6063-T6 3-7/32" x 1-7/8" extruded aluminum channels with four patented incorporated channel embossments. Each channel houses two or three flanged wheel assemblies, positioned under each shelving upright post or back-to-back posts, transferring the load to the track. Wheels are 1215 steel, 3-1/4" diameter, supported by two, mounted flanged ball bearings. Channels are drilled with computerized axle drilling at all wheel locations to guarantee precision. Idler rolling wheels mounted via lubricated and sealed ball bearing race with 3/16" sideways movement with both having precision machined steel axles. All wheel channels have drive wheels. The drive wheels are attached to drive box sprocket, full length, via 1" diameter .096 wall steel tube. For ease of transportation and handling, carriages longer than 144" will be shipped in left and right halves with one factory prepared lap splice per carriage. Height from floor to top of carriage angle (shelving mounting surface) shall not be more than 4-5/16".



FLAT TRACK MECHANICAL-ASSIST DRIVES: The carriage will have mechanically assisted 16:1 ratio drive system which drives wheels in the carriage channels the full length of the carriage to eliminate "lag". The carriage will have a low profile, drive box assembly, protruding no more than 5-1/2" from the front of the carriage. The drive box is covered by a durable 1/8" thick ABS with texture black cover. An ergonomically designed single prong handle molded of industrial strength polymer, colored black with a mate grain finish, creates easy carriage movement. The handle assembly includes a large "detent" to push for releasing the carriage safety parking/locking mechanism. The Detent is spring loaded to ensure the carriage will stay locked when engaged. An optional key lock shall be available and be easily field installed. The drive box upper and middle sprockets will be connected by a 95 link #41 roller chain and the middle and lower sprockets connected by a 87 link #41 roller chain, each with an average tensile strength of 2700 lbs. and a minimum ANSI strength of 1500 lbs. Chain tensions are to be maintained by use of upper and lower chain steel and nylon idlers which are attached to the drive box assembly and are fully adjustable. One handle turn/drive revolution drives the carriage, approximately 3-1/2".



Flat Track Mechanical-Assist (SDF) System Specifications

FLAT TRACK: Standard track construction is 3-1/4" wide X 1/2" high, 6063 aluminum extrusion base with 3/4" x 3/8" 1018 cold roll steel wheel rolling insert to provide 3/4" wide, matched to wheel hardness, wheel-to-insert contact surface for strength and durability. Track shall be top of floor mounted and ADA compliant to eliminate need for deck and ramp and designed to carry a maximum load of 1,000 lbs. per linear carriage foot. Track sections will have lap splices, no butt joints nor exhibit movement or deflection during operation of movable carriages. Track will be fastened to the floor through factory drilled and countersunk hole in steel rolling insert, so screw head will be flush or below top of steel, and matching slot in the aluminum extrusion using 1/4 x 2" Hilti Sleeve Anchors placed on average 16" apart.

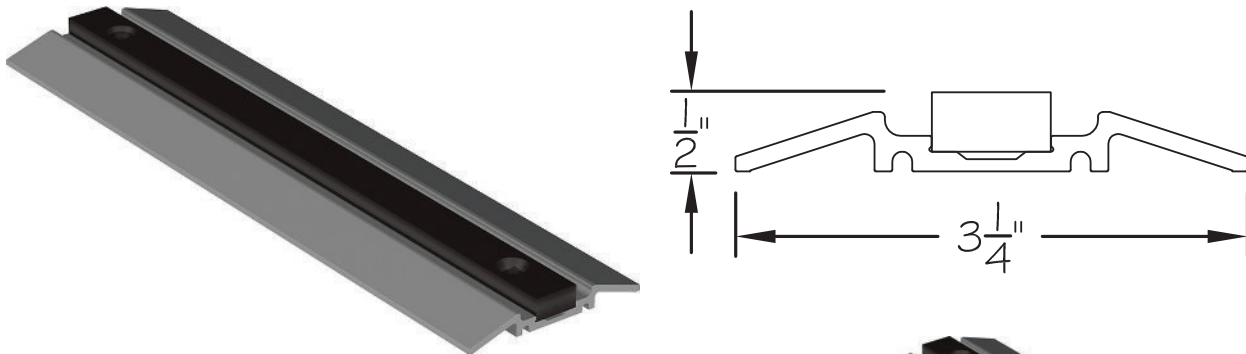

FLAT TRACK END STOPS: Standard track end stop is 1-1/2" diameter rubber cushion reinforced with an internal steel washer. End stop attached at each end of track run through pre-drilled factory hole with Hilti II 1/4" x 3-1/4" anchor.



IN-TRACK ANTI-TIP OPTION: (Recommended when carriage/shelving height-to-depth ratio exceeds 4:1 of or in Seismic risk areas.) Steel anti-tip arms (attached to the inside of the carriage) travel in the track anti-tip rail as the carriage is moved along the track. By design, the anti-tip is riding in exact relationship to the wheel axles, always allowing the anti-tip to float free of drag or binding as it moves along the track. Installed, the track is anchored to the floor with Hilti TZ anchors, and the shelving is secured to the carriage. Can be employed on carriages up to 12' in length. The track is 5.3" wide and 0.6" high.

Z-RAIL ANTI-TIP OPTION: (Recommended when carriage/shelving height-to-depth ratio exceeds 4:1 of or in Seismic risk areas.) Steel, floor mounted "Z" shaped rail provides a lip under which Z-Rail anti-tip arms (attached to the inside of the carriage) are free to travel as the carriage is moved along the track. If the carriage begins to tip, the arm immediately engages the Z-Rail to prevent tipping. Installed, the Z-Rail is anchored to the floor and the storage units are secured to the carriages. The vertical height of the Z-Rail is 1".



COLOR: Silver Aluminum with Black Trim (Mechanical-Assist Drive Cover, Carriage Corner & Center Plates) is standard.